

**Total No of Pages : 02**

**A.D.PATEL INSTITUTE OF TECHNOLOGY**  
**First Year (1st Sem) Internal Exam [GTU] – CP, EC IT, EE**

**SUB: Engineering Graphics**

Date:19-10-08

Time : 08:00 to 09:00 am

Marks : 20

- Note: (01) Retain all the construction Lines  
(02) Use both the side of Drawing Sheets  
(03) Don't draw border lines and title block

- Q-1 Draw the Ellipse by concentric circle with major axis 100 mm and minor axis 60 mm **04**
- Q-2 OBA is a simple slider crank chain as shown in fig 01. OB is a crank of 30 mm length. BA is a connecting rod of 90 mm length. Slider A is sliding on a straight path passing through point O. Draw the locus of the mid-point of the connecting rod AB for one complete revolution of the crank OB. **04**
- Q-3 A string is unwound from a circle of 20 mm diameter. Draw the locus of string P for unwinding the string's one turn. String is kept tight during unwound. Draw tangent & normal to the curve at any point. **06**
- OR**
- Q-3 Draw the following view of the given figure-02 by using first angle projection method **06**
- (i) Front View  
(ii) Top View  
(iii) Right Hand Side View
- Q-4 The front view of a 100 mm long line AB measures 65 mm. A is 50 mm above H.P. and 25 mm in front of V.P. B is 20 mm above H.P. and in front of V.P. Draw the projections of line and find out the length of top view, true inclination of the line and apparent inclination with both the reference planes. **06**
- OR**
- Q-4 A regular pentagonal plate of 30mm sides, has one of its corners on H.P. The plane of the pentagon is inclined at 45° to the H.P. The side of the pentagon, which is opposite to the corner, which is on H.P. is inclined at 30° to the V.P. Draw the projections of the plate. **06**

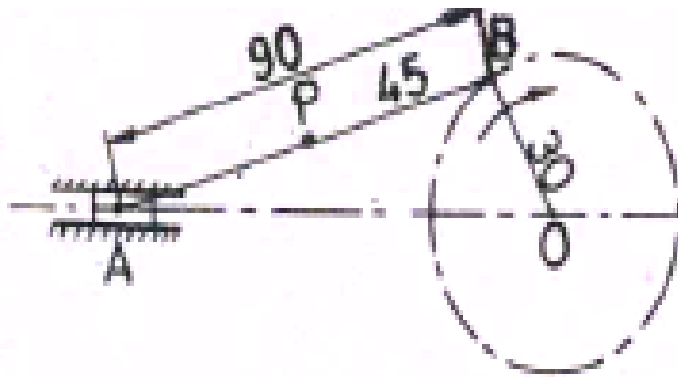

Figure -01

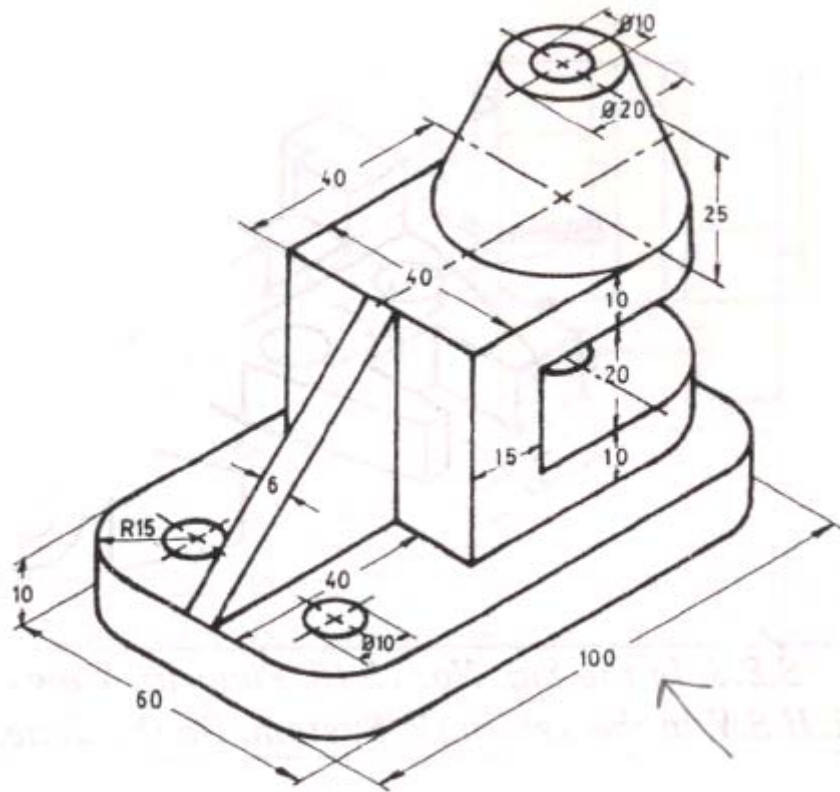

Figure -02